

General Specifications

Case & Ring: Hermetically sealed 300 series stainless steel
 Adjustable Bracket: 300 series stainless steel
 Lens: Double strength glass
 Dial: Anti-parallax, aluminum with white finish and black markings.
 Pointer: Black
 Recalibrator: External recalibrator on rear of the case
 Connection: 300 series stainless steel, 1/2"NPT
 Stem: 300 series stainless steel Ø0.250" with silicone dampening.
 Accuracy: ±1% full range (ASME B40.3 Grade A)
 Conforms with ASME B40.200
 Ambient Temperature: -40 to 250°F (-40 to 120°C)

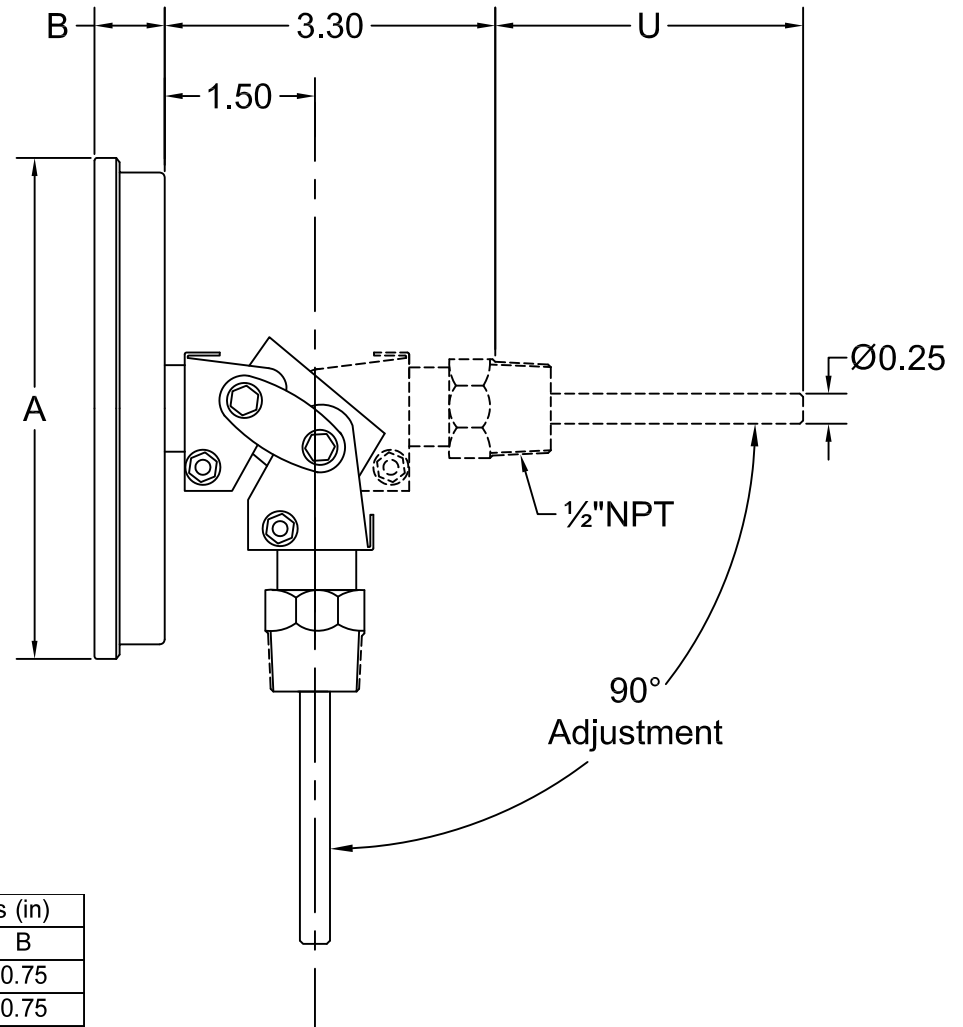

Temperature Range	°F Scale		°C Scale		Catalog Number
	Fig.	Div.	Fig.	Div.	
-40 to 160°F & -40 to 70°C	20	2	10	1	39
25 to 125°F & -5 to 50°C	10	1	5	0.5	43
0 to 250°F & -20 to 120°C	50	2	20	2	54
50 to 300°F & 10 to 150°C	50	2	20	2	63
50 to 500°F & 10 to 260°C	50	2	20	2	94
150 to 750° & 50 to 400°C	100	10	50	5	65
200 to 1000°F & 100 to 530°C	100	10	50	5	59

Type	Stem Length - "U"					Dimensions (in)	
	2.5"	4.0"	6.0"	9.0"	12.0"	A	B
3" Dial	B3099A -2	B3099A -4	B3099A -6	B3099A -9	B3099A -12	3.0	0.75
5" Dial	B5099A -2	B5099A -4	B5099A -6	B5099A -9	B5099A -12	5.0	0.75

Customer: _____

Project: _____

Engineer: _____

Pro or PO#: _____

MILJOCO
 CORPORATION 200 Elizabeth Street, Mt. Clemens, Michigan 48043 USA

SCALE: None	APPROVED BY:	DRAWN BY: HMT
DATE: 4/19/17		REVISED:

5" & 3" Adjustable Bi-metal Thermometer

PART NUMBER: B5099A & B3099A	DRAWING NUMBER: 127-93
DIMENSIONS: Inches [Metric] Inches: .xx ± .010 .xxx ± .005 [Metric]: .xx ± .25 .xxx ± .13	